

**HUMMER**

**H-500**

**DIGITAL ARGB CPU COOLER**

**USER MANUAL**

# 01.PACKAGE CONTENT

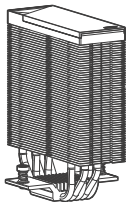
**A**

x1

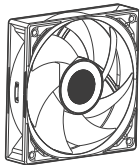
**B**

x1

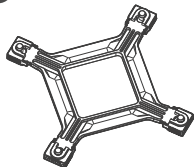
**C**

1 x

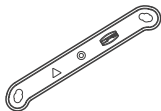
**D**

x2

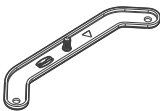
**E**

x2

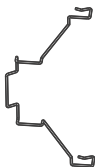
**F**

x2

**G**

x1

**H**

x4

**I**

x4

## 2.INTEL&AMD

AMD AM5/AM4:E,H,I

INTEL LGA 1851 /1700/1200/115X:C,D,H,I

**H**



**I**

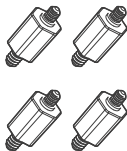

**C**

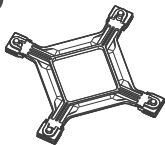

**D**

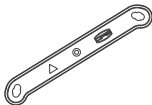

**E**

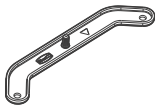

**INTEL**

**AMD**

### 03.INTEL&AMD

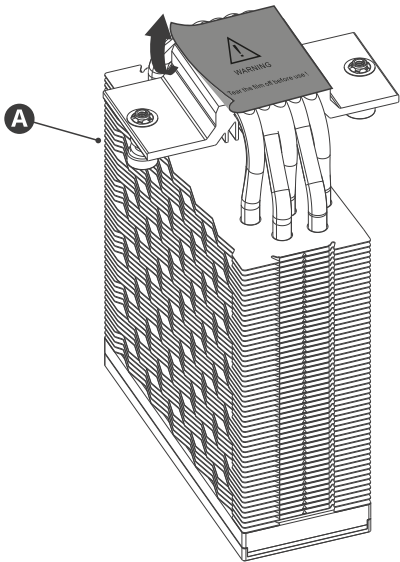

# 04.INTEL-LGA 1851/1700/1200/115X

1

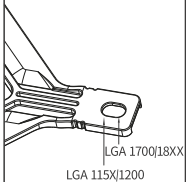

2

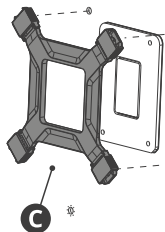

4

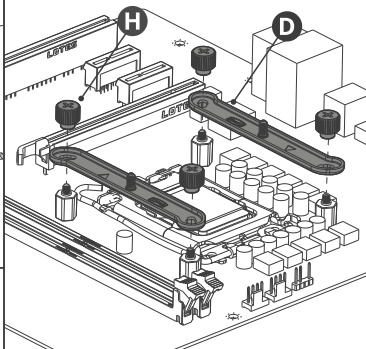

3

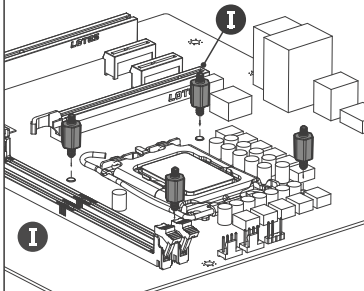

D

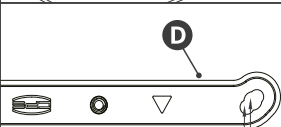

## 05.INTEL-LGA 1851/1700/1200/115X

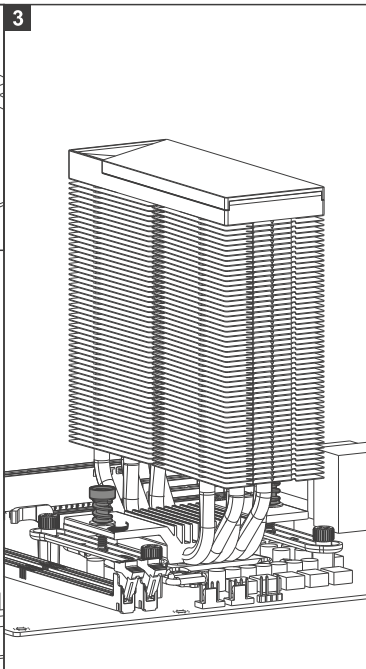
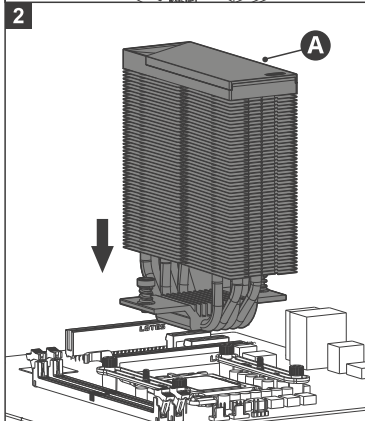
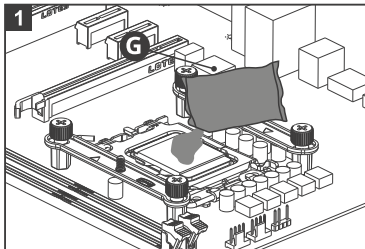

## 06.AMD-AM5/AM4

1

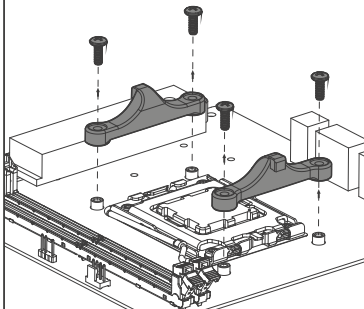

2

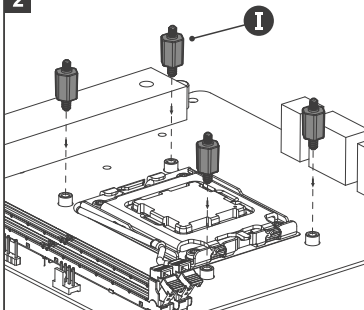

3

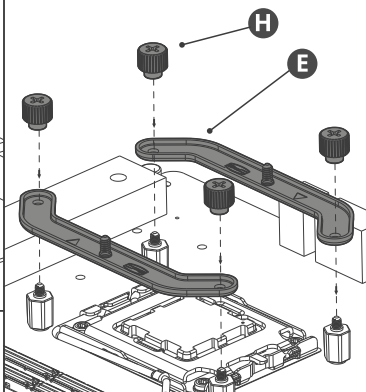

AM4/AM5

## 07.AMD-AM5/AM4

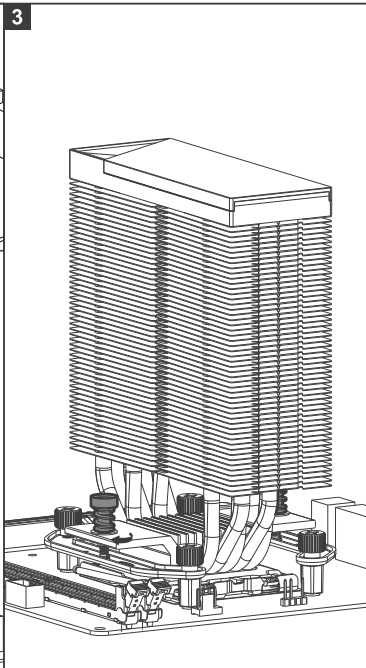
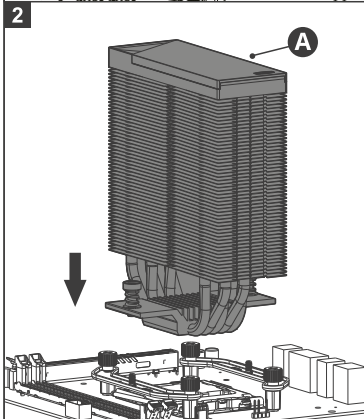
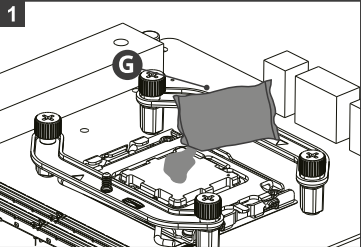



## 08.INTEL&AMD

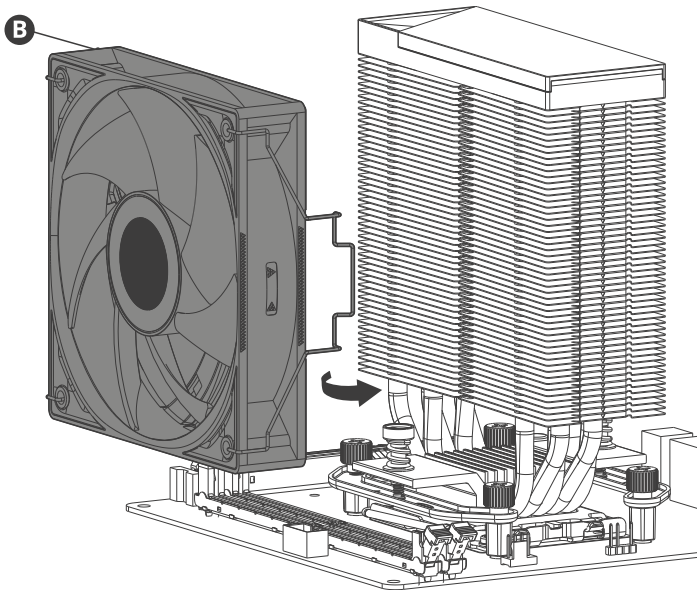

## 09.INTEL&AMD

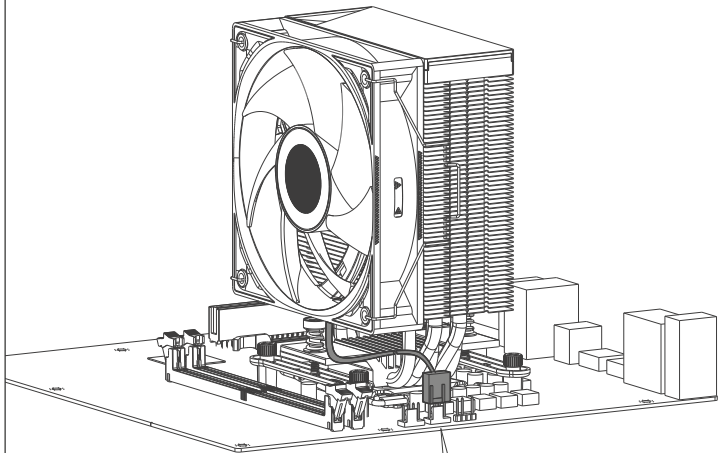

CPU\_FAN

## 10. INTEL&AMD ARGB

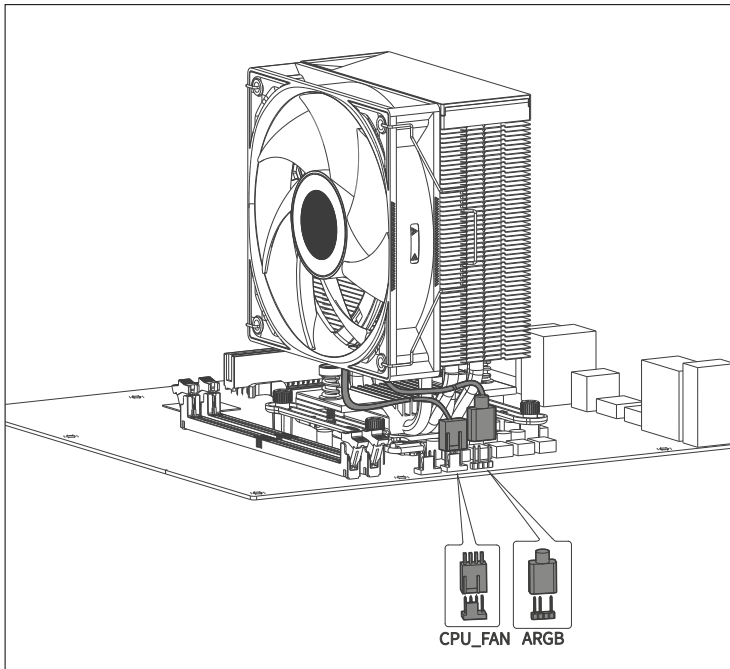

## 11. INTEL USB

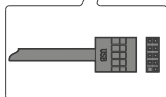
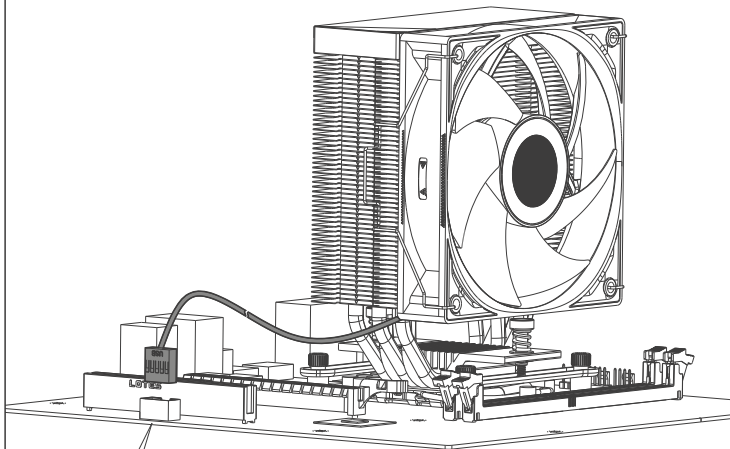

Connect to 9-pin USB

## 12.AMD USB

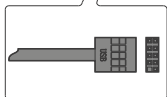
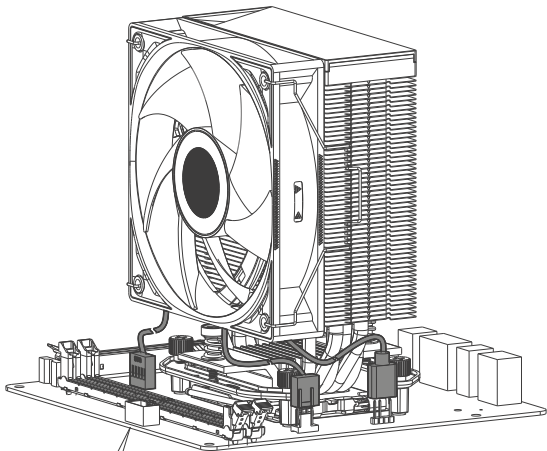

**Connect to 9-pin USB**

## 13. PRODUCT SOFTWARE

Go to NOX website, [www.nox-extreme.com](http://www.nox-extreme.com).

Go to the cooling system section and search for Hummer H-500.

You will find a link to download the software.

Install it and follow the instructions.

Enjoy Hummer H-500 Digital ARGB CPU Cooler.

POWERED BY  
**NOX**

[www.nox-extreme.com](http://www.nox-extreme.com)